

Experience
Innovation
Quality
Profitability

OLETTO

Thermo Asphalt Container/Hot-Box



The OLETTO Hot-Box/Thermo Asphalt Container keeps the asphalt hot all day and is the ideal pothole patcher for repairing asphalt surfaces after laying pipelines or any other depositing of small amounts of bitumen (asphalt), etc.

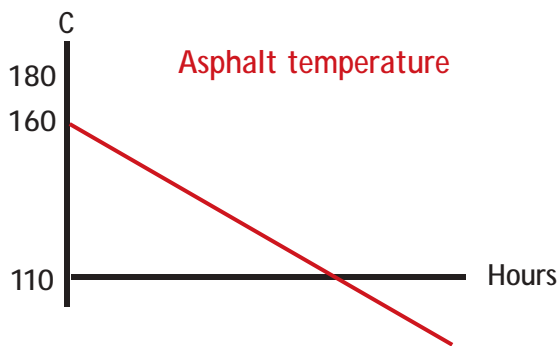

Insulation keeps the temperature high

Loading doors for filling

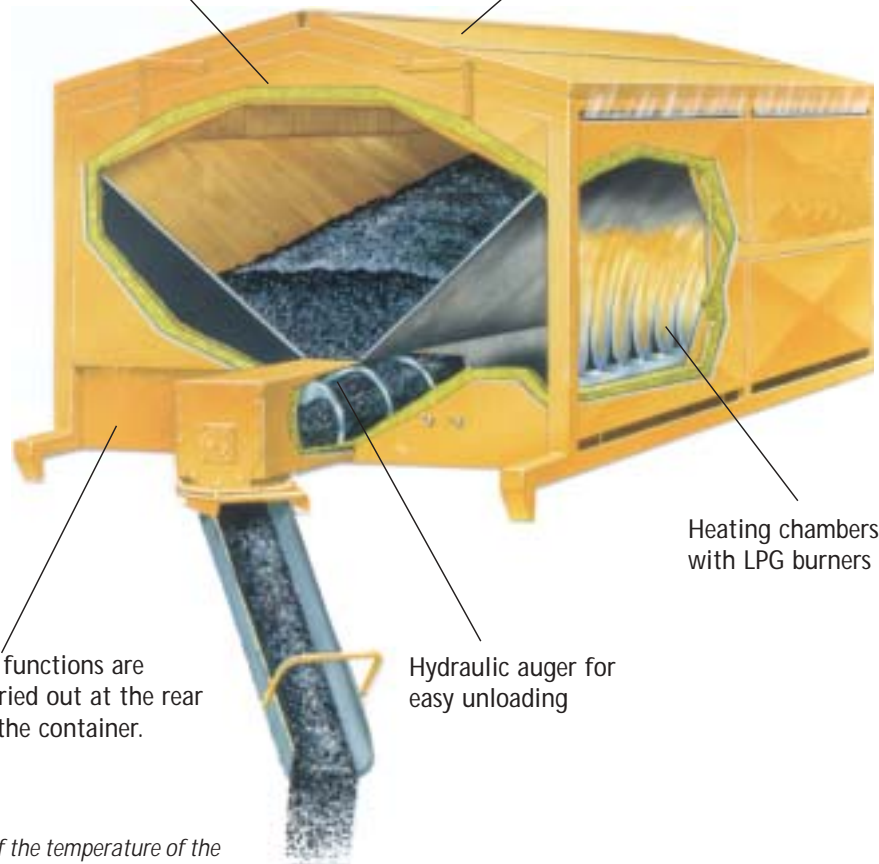

All functions are carried out at the rear of the container.

Hydraulic auger for easy unloading

Heating chambers with LPG burners

If the temperature of the bitumen goes below 115°C the quality of the repair is unacceptable and will not last long time. And result will be as on the photo up left.



Efficiency in Road Maintenance

OLETTO Thermo Asphalt Container/Hot-Box

SOME ADVANTAGES OF THE OLETTO HOT-BOX*



Electrical control of valves



Remote control as option



Computerized control of heating



Gas bottles can be placed from side or rear



Platform in front side is standard



Doors opens flat and with tight flaps



Fastening eyes



Turnable chute is standard

DRIVE AND HYDRAULIC OPTIONS:



Hydraulic from lorry



11 HP Honda engine (for AF 25 only)



13 HP Honda engine for petrol and gas



20HP Hatz diesel engine. Standard or super Silent

HOW TO TRANSPORT AND STORE THE BOX:



Permanent on a lorry



Permanent on a trailer



Mechanical legs for lorry with tipper



Hydraulic legs. For any kind of lorry - also for full box



Multi lift system

* Some features are not valid for AF25

Efficiency in Road Maintenance

OLETTO Thermo Asphalt Container/Hot-Box

SEPARATE ACCESSORIES



Dicky box



Deposit box (mini paver)



Hydraulic hammer



Extended chute for high lorry

INTEGRATED ACCESSORIES AND OPTIONS



Twin chamber



Hardox auger



Twin chamber



2,2 m External conveyor belt



2,2 m External conveyor auger



Auger inspection and cleaning door with safety switch



External Hydraulic Take off



External gas burner



Bituslip sprayer



Hydraulic opening of loading doors



Electrical heating of auger



Crane for gas bottles



Fire extinguisher in box



Rotating beacon



Built-in Bonding agent tank

MODEL	AF25	AF50	AF50/2K	AF75	AF75/2K	AF100	AF100/2K	AF100/H	AF100/2K/H
Chambers	1	1	2	1	2	1	2	1	2
Thermometer	Analogue *)	Digital	Digital	Digital	Digital	Digital	Digital	Digital	Digital
Temperature regulation	Manual *)	Automatic	Automatic	Automatic	Automatic	Automatic	Automatic	Automatic	Automatic
Burner type	Direct flame	Lamella	Lamella	Lemella	Lamella	Lamella	Lamella	Lamella	Lamella
Max. volume m ³	1,4	2,8	3,4	4,2	5,1	5,5	6,9	7,5	8,8
Max. capacity t	3,1	6,2	7,5	9,3	11,4	12,2	15,5	16,7	19,6
Lorry pay load t	4,0	7,78	9,2	11,1	13,4	14,3	17,9	18,9	22,0
Tare weight kg	950	1500	1700	1800	2000	2100	2350	2200	2450
Gas consumption kg/h	1	2	2	3	3	4	4	5	5
Standard colour, yellow**	RAL 1007								
Insulation	Sides and top: 50 mm. Bottom: 30 mm								
Gas pressure	1 bar								

*) The AF 25 can be equipped with automatic thermostatic temperature control

***) All colours can be chosen

Model:	AF25	AF50	AF50/2K	AF75	AF75/2K	AF100	AF100/2K	AF100/H	AF100/2K/H
A	2765	3810	3810	4810	4810	5810	5810	5810	5810
B	410	550	550	550	550	550	550	550	550
C	1605	2300	2300	3300	3300	4300	4300	4300	4300
D	750	800	800	800	800	800	800	800	800
E	410	460	460	460	460	460	460	460	460
F	1560	2460	2460	3460	3460	4460	4460	4460	4460
G	250	250	250	250	250	250	250	250	250
H	1620	1620	1700	1620	1700	1620	1700	1950	2030
I	1600	2000	2000	2000	2000	2000	2000	2000	2000

All dimensions are in mm. Dimensions and specifications are subject to modifications without notice.

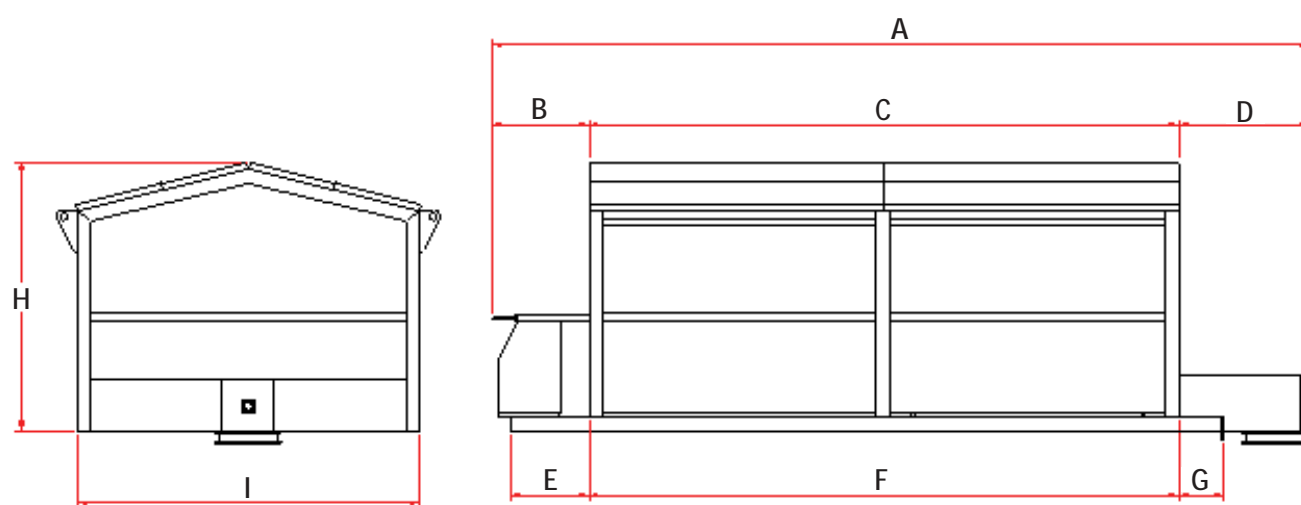

Manufacture:

Dan-varme

Falkevej 14
 Balling, DK-7860 Spøttrup, Denmark
 Phone: +45 97 56 41 08
 Fax: +45 97 56 47 34
 E-mail: bs@danvarme.dk

Sale outside Denmark:

OLETTO SALES

Haandvaerkervej 159
 DK-8600 Silkeborg, Denmark
 Phone: +45 70 23 24 98
 Fax: +45 70 20 62 37
 E-mail: oletto@rostech.dk
 www.oletto.dk

Distribution: